



The natural solution

# Model M10 Specification Sheet

## Capacity

M10 Volume: 90 cubic feet; 755 US gallons  
Daily capacity at average temp.  $\geq 65^{\circ}\text{F}$ : 60 visits  
Annual capacity at average temp.  $\geq 65^{\circ}\text{F}$ : 22,500 visits

## Specifications and Materials

### Dimensions

Length: 101"; Width: 44"; Height: 55"  
Weight: 300 lbs  
Working Area on Top of Composter: 30"x48"  
Waste Access Door: 10"x30" on composter front  
Compost Access Lid: 32"x44" on composter front  
Polyethylene Wall Thickness: .375" nominal

### Materials

The M10 Modular Composter is rotationally molded using linear polyethylene resin that conforms with the following specifications:

Density (ASTM TEST D 4883): 0.938 g/cm<sup>3</sup>  
Tensile Strength at Yield (ASTM D 638): 2750 psi  
Dart Impact (-40°C, 250 mils thickness): 145 ft-lbs  
Envt. Stress Crack Resistance (D 1693): >1,000 hrs

### Ventilation

**AC:** 115V, 93w, 60 Hz, .72 amp fan with 243 cfm at free air. Fan made of GE Noryl plastic, totally enclosed, ball-bearing motor, in-line, direct drive. UL and CSA approved. Diameter: 11.75"; Inlet/Outlet Diameter: 5.87"; Length: 7.75". The fan is mounted in-line near the composter, within 4" PVC or ABS ducting (not included). **12 V DC available.**

### Automatic Moistening System

An automatic control device monitors daily compost mass moistening. Timer is housed in water-resistant NEMA box. Spray time is preset at factory.

**Components:** Solenoid-120VAC, 50/60Hz, UL and CSA listed. Timer-Synchronous motor, 48 max. on-off cycles, 120VAC, 0.1watts. **12 V DC available.**

### Liquid Removal Pump

**AC:** Submersible, 115V, 5 amp, with 18', 3-conductor, oil-resistant cord. UL and CSA approved. 1" NPT liquid discharge outlet. Capacity is 20.4 gallons per minute at 1' with a maximum pumping height of 26.3'.

**12 V DC available.**

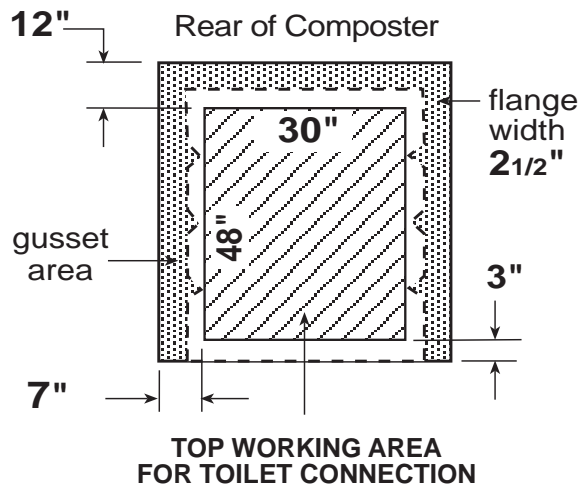
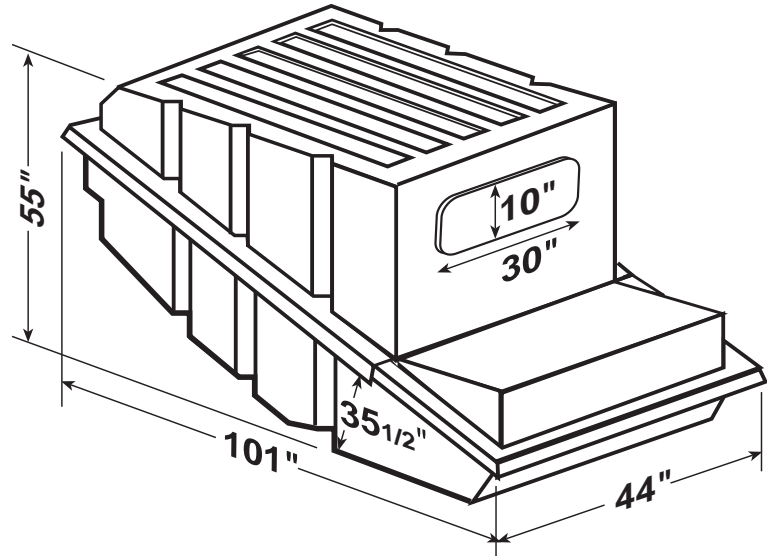

### Wood Composter Support Cradle Kit

Supports the M10 Composter. Made from pressure treated lumber.

### Toilet

The **Waterless Toilet** is constructed of impact resistant fiberglass with a sanitary white gel-coat finish. The seat and lid are made of plastic; the liner is made of rotationally molded polyethylene. The toilet must be located directly over the composter, which is situated in a space or room below. The toilet is connected with a 14" diameter straight chute.

Toilet height: Standard - 14"; Handicapped - 18"  
Width: 18.5"; Length: 24.25"



DISTRIBUTED BY:  
Clivus New Englad, Inc.  
P.O. Box 127  
North Andover, MA 01845  
978.794.9400  
Fax: 978.794.9444  
www.clivusne.com